

MACROLUX

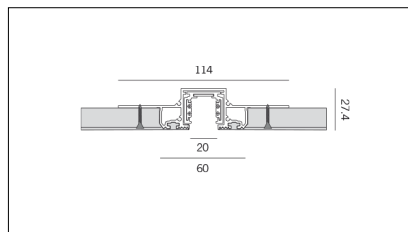

Codice Articolo	Articolo	Colore	Lunghezza (mm)	Colore addizionale
1305.0248.94	ME_248-94 L=max 3m	Bianco (94)		
1305.0248.K1.94	ME_248/1000/48V-94	Bianco (94)	1000	Bianco (4)
1305.0248.K2.94	ME_248/2000/48V-94	Bianco (94)	2000	Bianco (4)
1305.0248.K3.94	ME_248/3000/48V-94	Bianco (94)	3000	Bianco (4)

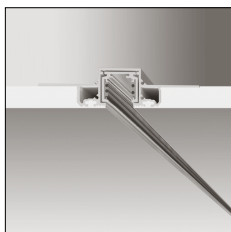
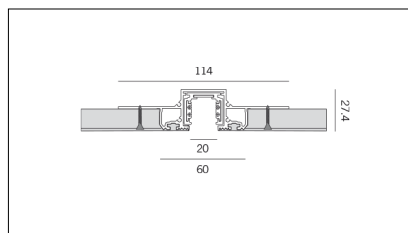
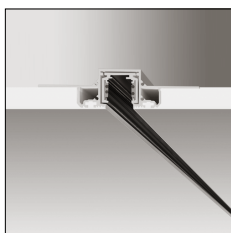

Codice Articolo	Articolo	Lunghezza (mm)	Colore addizionale	Colore
1305.0248.K1.942	ME_248/1000/48V-942	1000	Nero (2)	Bianco/Nero (942)
1305.0248.K2.942	ME_248/2000/48V-942	2000	Nero (2)	Bianco/Nero (942)
1305.0248.K3.942	ME_248/3000/48V-942	3000	Nero (2)	Bianco/Nero (942)

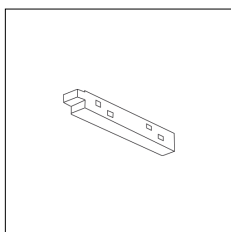

Codice Articolo	Nome	Descrizione	Colore
1305.6048.92	ME_48/AL-92	Testata di alimentazione per binario 48V a plafone - Finitura nero	Nero (92)

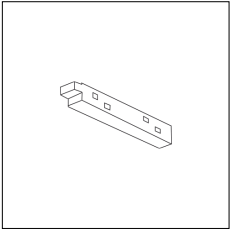

Codice Articolo	Nome	Descrizione	Colore
1305.6048.94	ME_48/GL-94	Testata di alimentazione per binario 48V a plafone - Finitura bianco	Bianco (94)

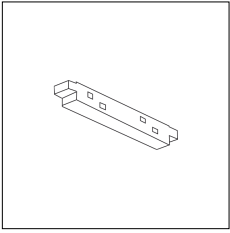

Codice Articolo	Nome	Descrizione	Colore
1305.1048.92	ME_48/GL-92	Giunzione lineare per binario 48V - Finitura nero	Nero (92)

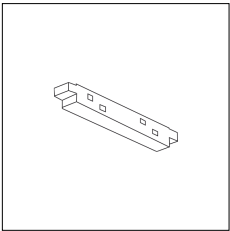

Codice Articolo	Nome	Descrizione	Colore
1305.1048.94	ME_48/GL-94	Giunzione lineare per binario 48V - Finitura bianco	Bianco (94)

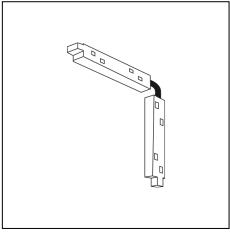

Codice Articolo	Nome	Descrizione	Colore
1305.7048.92	ME_48/GA-92	Giunzione angolare per binario 48V a plafone - Finitura nero	Nero (92)

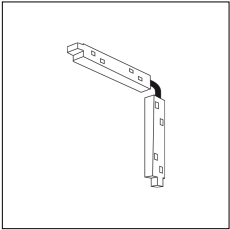

Codice Articolo	Nome	Descrizione	Colore
1305.7048.94	ME_48/GA-94	Giunzione angolare per binario 48V a plafone - Finitura bianco	Bianco (94)

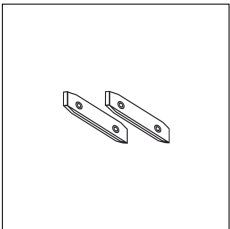

Codice Articolo	Nome	Descrizione
1312.1030	ML_30/GL	Staffe di giunzione lineare - Compatibile con ML_30, MT2_27 e MX2_27
1312.1030.10	ML_30/GL - 10 PZ	Staffe di giunzione lineare - Compatibile con ML_30, MT2_27 e MX2_27

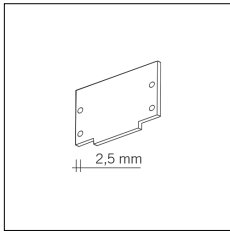

Codice Articolo	Nome	Descrizione	Colore
1305.5248.94	ME_248/TC-94	Testata di chiusura l End cap	Bianco (94)



Codice Articolo	Nome	Descrizione
1305.2248	ME_248/G090 (Solo taglio)	Taglio ad angolo orizzontale 90° / Horizontal corner's cut 90°



Codice Articolo	Nome	Descrizione
1305.3248	*Taglio angolare orizzontale 270°	

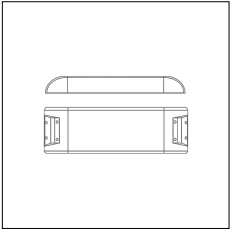

Codice Articolo	Nome	Descrizione	Potenza (W)	Tipo di Driver
1.048075	Driver Constant Voltage 77W/48V IP67	Driver Costant Voltage 48V: 200-305V/76.8W 100-180V/60W	77	On/Off

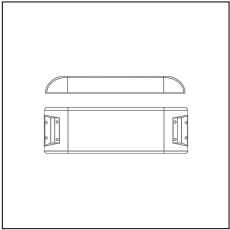

Codice Articolo	Nome	Descrizione	Potenza (W)	Tipo di Driver
1.048100	Driver Constant Voltage 100W/48V IP67		96	On/Off

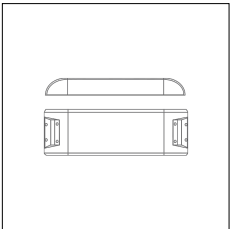

Codice Articolo	Nome	Descrizione	Potenza (W)	Tipo di Driver
1.048150	Driver Constant Voltage 150W/48V IP67	Driver Costant Voltage 48V: 200-305V/150W 100-180V/105W	150	On/Off

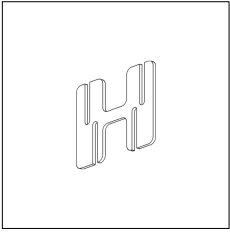

Codice Articolo	Nome	Descrizione
1324.7227.1	M2_27/KEY	Chiave per fissaggio per MA2_35, MX2_27 e MT2_27

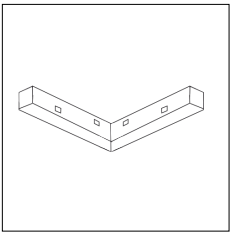

Codice Articolo	Nome	Descrizione	Colore
1305.7148.92	ME_48/GO-92	Giunzione ad angolo orizzontale 90° per binario 48V a plafone - Finitura nero	Nero (92)

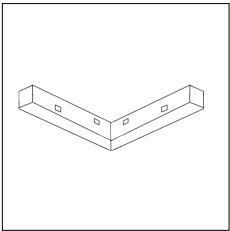

Codice Articolo	Nome	Descrizione	Colore
1305.7148.94	ME_48/GO-94	Giunzione ad angolo orizzontale 90° per binario 48V a plafone - Finitura bianco	Bianco (94)

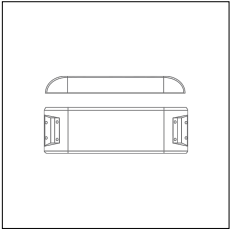

Codice Articolo	Nome	Descrizione	Potenza (W)	Tipo di Driver
1.048240	Driver Constant Voltage 240W/48V IP67	Driver Costant Voltage 48V: 200-305V/240W 100-180V/180W	240	On/Off

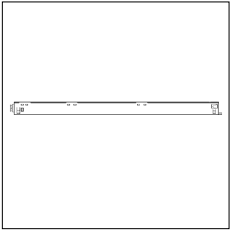

Codice Articolo	Nome	Descrizione	Potenza (W)	Tipo di Driver	Colore
1.048100.H	Driver Constant Voltage 100W/48V IP20 BLACK	Driver Costant Voltage 48V: 220-240V/100W Driver "invisibile" per alimentazione diretta completo di cablaggio	100	On/Off	Nero (92)

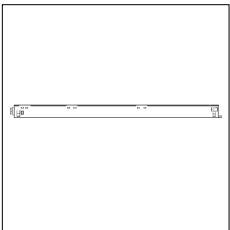

Codice Articolo	Nome	Descrizione	Potenza (W)	Tipo di Driver	Colore
1.048100.H94	Driver Constant Voltage 100W/48V IP20 WHITE	Driver Costant Voltage 48V: 220-240V/100W Driver "invisibile" per alimentazione diretta completo di cablaggio	100	On/Off	Bianco (94)